

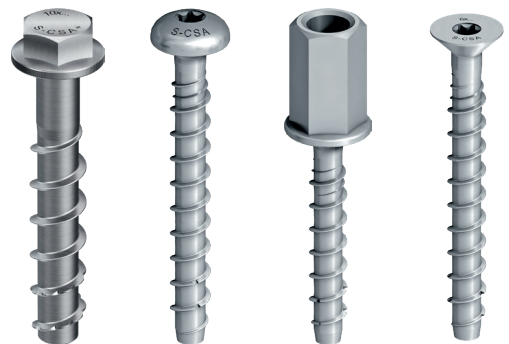

















Concrete screws

Technical Specifications









Bringing it together.

Concrete screws product overview

Screw	JC2-KB	JC2-FR	JC2-ST	JC2-IT	JC2-KB Plus
					
Material	Galvanised or zinc alloy coated carbon steel				
Applications	Facade scaffolds, temporary fastening, contact surfaces, shelves, cable racks, hand rails, battens			Pipe brackets, profile rails	Facade scaffolds, temporary fastening, contact surfaces, shelves, cable racks, hand rails, battens, formworks
Drive					   
Cracked concrete ETAG-001-1	Ø 6 - 14 mm				
Cracked concrete ETAG-001-6	Ø 6 mm			-	
Non-cracked concrete	Ø 6 - 14 mm				
Certifications	 				
Fire resistance					
Mode of action	Undercut				
Type of load	static				
Recommended tensile loads	1.4 - 4.5 kN			3.1 - 14.3 kN	
Recommended shear loads	3.1 - 5.6 kN			10.9 - 37.1 kN	

Approvals / Certifications / Applications

Description of document		Authority/ Laboratory	ID	Additional info
European Technical Assessment		ZAG -National Building and Civil Engineering Institute, Slovenia	ETA-17/0835 JC2 6, 8, 10	EAD 330232-00-0601, Option 1
European Technical Assessment		ZAG -National Building and Civil Engineering Institute, Slovenia	ETA-18/0221 (JC2 6)	Concrete screw of size 6 for multiple use in non-structural applications, EAD 330747-00-0601, (Part 6)
European Technical Assessment		ZAG -National Building and Civil Engineering Institute, Slovenia	ETA-21/0020 (JC2 Plus 8, 10, 14)	EAD 330232-00-0601, Option 1
Fire resistance		ZAG -National Building and Civil Engineering Institute, Slovenia	ETA-17/0835 ETA-18/0221 ETA-21/0020	
EJOT Anchor Fix calculation software		EJOT Software		Free download: https://www.ejot.com/software-anchorfix

Additional information concerning all given data in the product data sheet

- > Load figures include the partial safety factors as per approvals and a partial safety factor on the action of $\gamma_F = 1.4$. Load figures apply for a rebar spacing $s \geq 15$ cm or alternatively for a rebar spacing $s \geq 10$ cm in combination with a rebar diameter of $d_s \leq 10$ mm.
- > If spacings or edge distances become smaller than the characteristic figures ($s_{cr,N} / c_{cr,N}$) a calculation as per EOTA TR 055 needs to be carried out. For more details, see ETA-17/0835, ETA-18/0221 and ETA-21/0020.
- > Concrete is considered non-cracked when the value of tension within the concrete is $\sigma_L + \sigma_R \leq 0$. In the absence of detailed verification $\sigma_R = 3$ N/mm² can be assumed (σ_L equals the tension within the concrete as a result of external loads, forces on anchor included; σ_R equals the tension coming from shrinkage or creep of the concrete, as well as displacements of supports or temperature variations).
- > Shear load figures apply for an anchor without influence of a concrete edge. For shear loads close to an edge ($c \leq 10 \times h_{eff}$), concrete edge failure has to be checked as per EOTA TR 055 or EN 1992-4.

Static and quasi-static loads

Characteristic resistances

Anchor size			JC2 6			JC2 Plus 8		JC2 Plus 10		JC2 Plus 14	
			PART 6	PART 6	OPT 1	OPT 1	OPT 1	OPT 1	OPT 1	OPT 1	OPT 1
Effective anchorage depth	h_{ef}	[mm]	27.6	31.9	42.5	39.2	51.9	42.5	68.0	49.3	91.8
Nominal anchorage depth	h_{nom}	[mm]	35	40	55	50	65	55	85	65	115
Non-cracked concrete											
Tensile	N_{Rk}	[kN]	3.0	3.5	9.5	12.1	18.4	13.6	27.6	15.0	42.0
Shear	V_{Rk}	[kN]	9.4*	9.4*	9.8*	19.1*	21.5*	31.8*	35.2*	56.2*	64.9*
Cracked concrete											
Tensile	N_{Rk}	[kN]	3.0	3.5	4.5	6.5	12.0	7.5	19.0	8.5	30.0
Shear	V_{Rk}	[kN]	9.4*	9.4*	9.5	19.1*	21.5*	28.6	35.2*	39.3	64.9*

*Failure mode = steel

Design resistances

Anchor size			JC2 6			JC2 Plus 8		JC2 Plus 10		JC2 Plus 14	
			PART 6	PART 6	OPT 1	OPT 1	OPT 1	OPT 1	OPT 1	OPT 1	OPT 1
Effective anchorage depth	h_{ef}	[mm]	27.6	31.9	42.5	39.2	51.9	42.5	68.0	49.3	91.8
Nominal anchorage depth	h_{nom}	[mm]	35	40	55	50	65	55	85	65	115
Non-cracked concrete											
Tensile	N_{Rd}	[kN]	2.0	2.3	6.3	8.0	12.3	9.1	18.4	10.0	28.0
Shear	V_{Rd}	[kN]	7.5*	7.5*	7.8*	15.3*	17.2*	25.4*	28.2*	37.5	51.9*
Cracked concrete											
Tensile	N_{Rd}	[kN]	2.0	2.3	3.0	4.3	8.0	5.0	12.7	5.7	20.0
Shear	V_{Rd}	[kN]	7.5*	7.5*	6.3	15.3*	17.2*	19.1	28.2*	26.2	51.9*

*Failure mode = steel

Recommended resistances

Anchor size			JC2 6			JC2 Plus 8		JC2 Plus 10		JC2 Plus 14	
			PART 6	PART 6	OPT 1	OPT 1	OPT 1	OPT 1	OPT 1	OPT 1	OPT 1
Effective anchorage depth	h_{ef}	[mm]	27.6	31.9	42.5	39.2	51.9	42.5	68.0	49.3	91.8
Nominal anchorage depth	h_{nom}	[mm]	35	40	55	50	65	55	85	65	115
Non-cracked concrete											
Tensile	N_{Rec}	[kN]	1.4	1.7	4.5	5.7	8.8	6.5	13.1	7.1	20.0
Shear	V_{Rec}	[kN]	5.4*	5.4*	5.6*	10.9*	12.3*	18.2*	20.1*	26.8	37.1*
Cracked concrete											
Tensile	N_{Rec}	[kN]	1.4	1.7	2.1	3.1	5.7	3.6	9.0	4.0	14.3
Shear	V_{Rec}	[kN]	5.4*	5.4*	4.5	10.9*	12.3*	13.6	20.1*	18.7	37.1*

*Failure mode = steel

The data of these tables is based on:

- > Concrete C20/25, $f_{ck,cube} = 25 \text{ N/mm}^2$
- > Installation has been done correctly
- > No influence of edge distances and spacings
- > Respect of minimum base material thickness

Basic loading data for precast pre-stressed hollow core slabs

Characteristic resistances

Anchor size			JC2 6		
Nominal anchorage depth	h_{nom}	[mm]		40	
Flange thickness	d_b	[mm]	25	30	40
Loading for all directions	F_{Rk}	[kN]	1.0	2.0	3.0
Char. bending resistance	$M_{Rk,s}^0$	[Nm]		16.0	
Edge distance	$c_{cr} = c_{min}$	[mm]		100	
Spacing	$s_{cr} = s_{min}$	[mm]		100	

Design resistances

Anchor size			JC2 6		
Nominal anchorage depth	h_{nom}	[mm]		40	
Flange thickness	d_b	[mm]	25	30	40
Loading for all directions	F_{Rd}	[kN]	0.7	1.3	2.0
Char. bending resistance	$M_{Rd,s}$	[Nm]		12.8	
Edge distance	$c_{cr} = c_{min}$	[mm]		100	
Spacing	$s_{cr} = s_{min}$	[mm]		100	

Recommended loads

Anchor size			JC2 6		
Nominal anchorage depth	h_{nom}	[mm]		40	
Flange thickness	d_b	[mm]	25	30	40
Loading for all directions	F_{Rec}	[kN]	0.5	1.0	1.4
Char. bending resistance	M_{Rec}	[Nm]		9.1	
Edge distance	$c_{cr} = c_{min}$	[mm]		100	
Spacing	$s_{cr} = s_{min}$	[mm]		100	

The partial safety factor for action is $\gamma = 1.4$

Requirements for multiple anchoring

The definition of multiple use acc. to the Member States is given in annex of the ETAG 001 Part 6

Minimum numbers of fixing points	Minimum numbers of anchors per fixing points	Maximum design loads of action N_{sd}
3	1	2 kN
4	1	3 kN

The value N_{sd} might be increased if in the design it is shown that the requirements on the strength and stiffness of the fixture in the serviceability and ultimate states after the failure of one anchor are fulfilled.

The data of these tables is based on:

- > Concrete C30/37 to C50/60
- > Installation has been done correctly
- > Edge distances and spacings
- > The data of these tables is based on ETA-18/0221

Setting instructions

Installation instructions in pre-stressed hollow core slabs

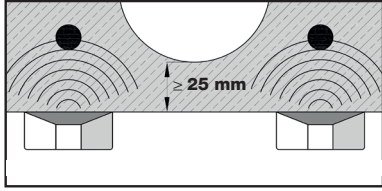

1. Locate rebars by means of suitable detector

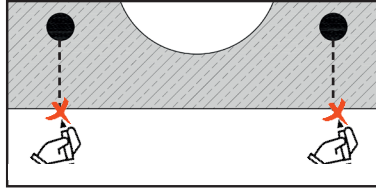

2. Mark rebar location

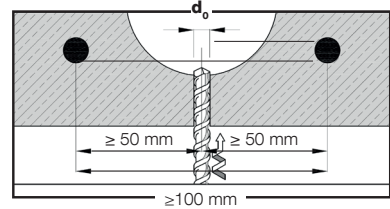

3. Make a cylindrical hole

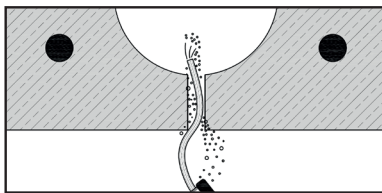

4. Clean the hole

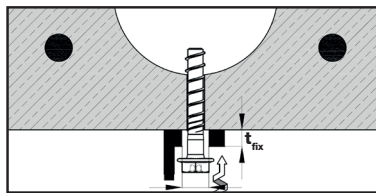

5. Install the screw anchor very gently by screw-driver or torque wrench. Avoid overtightening.

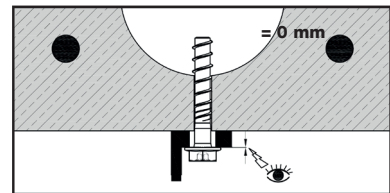

6. Ensure that the screw anchor head fully rests without any gap on the fixture and is not damaged

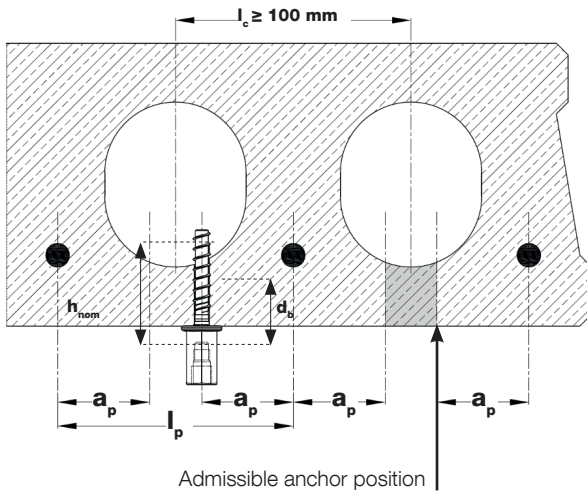

Admissible anchor position in pre-stressed hollow core slabs

Core distance	$l_c \geq 100 \text{ mm}$
Pre-stressing steel distance	$l_p \geq 100 \text{ mm}$
Distance between anchor position and prestressing steel	$a_p \geq 50 \text{ mm}$

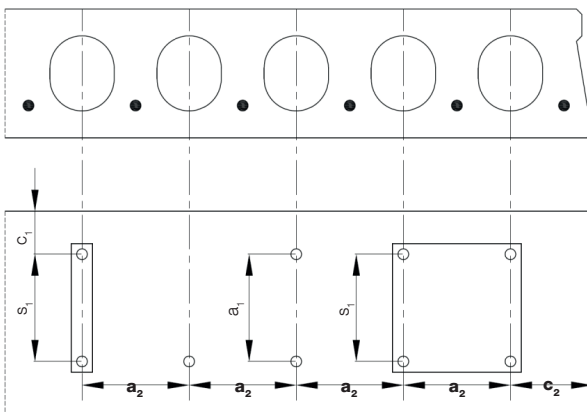

Minimum spacing and edge distance of anchors and distance between anchor groups in pre-stressed hollow core slabs

c1, c2	edge distance
s1, s2	anchor spacing
a1, a2	distance between anchor groups

Fire resistance



Design under fire exposure is performed according to the design method given in EOTA TR 020. The data of these tables is based on ETA-17/0835, ETA-18/0221 and ETA-21/0020.

Characteristic resistances

Anchor size			JC2 6			JC2 Plus 8		JC2 Plus 10		JC2 Plus 14	
			PART 6**	PART 6	OPT 1	OPT 1	OPT 1	OPT 1	OPT 1	OPT 1	OPT 1
Effective anchorage depth	h_{ef}	[mm]	27.6	31.9	42.5	39.2	51.9	42.5	68.0	49.3	91.8
Nominal anchorage depth	h_{nom}	[mm]	35	40	55	50	65	55	85	65	115
Fire Exposure R30											
Tensile	$N_{Rk,s,f}$	[kN]	NA	0.24	0.24	0.42	0.42	0.99	0.99	2.13	2.65
Shear (steel failure)	$V_{Rk,s,f}$	[kN]	NA	0.24	0.24	0.42	0.42	0.99	0.99	2.65	2.65
Fire Exposure R60											
Tensile	$N_{Rk,s,f}$	[kN]	NA	0.22	0.22	0.38	0.38	0.85	0.85	1.99	1.99
Shear (steel failure)	$V_{Rk,s,f}$	[kN]	NA	0.22	0.22	0.38	0.38	0.85	0.85	1.99	1.99
Fire Exposure R90											
Tensile	$N_{Rk,s,f}$	[kN]	NA	0.17	0.17	0.30	0.30	0.66	0.66	1.73	1.73
Shear (steel failure)	$V_{Rk,s,f}$	[kN]	NA	0.17	0.17	0.30	0.30	0.66	0.66	1.73	1.73
Fire Exposure R120											
Tensile	$N_{Rk,s,f}$	[kN]	NA	0.12	0.12	0.21	0.21	0.53	0.53	1.33	1.33
Shear (steel failure)	$V_{Rk,s,f}$	[kN]	NA	0.12	0.12	0.21	0.21	0.53	0.53	1.33	1.33

The recommended loads under fire exposure include a safety factor for resistance under fire exposure $\gamma_{M,fi} = 1.0$ and the partial safety factor for action $\gamma_{Fi} = 1.0$. The partial safety factors for action shall be taken from national regulations.

** Pending

The data of these tables is based on:

- > Concrete C20/25, $f_{ck,cube} = 25 \text{ N/mm}^2$
- > Values cannot be used with hollow core slabs
- > Installation has been done correctly
- > No influence of edge distances and spacings
- > Respect of minimum base material thickness

Material and dimensions

Material quality and coating

Part

Material	Cold forged carbon steel
Coating ZP	Zinc electroplated according to EN ISO 4042 $\geq 5 \mu\text{m}$
Coating ZA	Zinc alloy coating $\geq 8 \mu\text{m}$

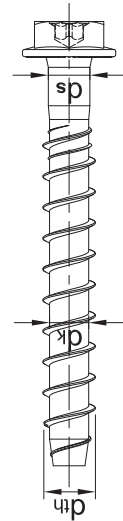

Mechanical properties

Specification		JC2 6			JC2 Plus 8		JC2 Plus 10		JC2 Plus 14	
		PART 6**	PART 6	OPT 1	OPT 1	OPT 1	OPT 1	OPT 1	OPT 1	OPT 1
Effective anchorage depth	h_{ef} [mm]	27.6	31.9	42.5	39.2	51.9	42.5	68.0	49.3	91.8
Nominal anchorage depth	h_{nom} [mm]	35	40	55	50	65	55	85	65	115
Nominal tensile strength	F_{tk} [N/mm ²]	800								
Char. bending resistance	$M_{Rk,s}^o$ [Nm]	16			37	45	72	84	207	227
Design bending resistance	M_{Rd} [Nm]	12.5			29.6	36	57.6	67.2	165.6	181.6
Recommended bending resistance	M_{rec} [Nm]	9.1			21.1	25.7	41.1	48	118.3	129.7

Specification		JC2 6	JC2 Plus 8	JC2 Plus 10	JC2 Plus 14
Nominal diameter	d_{nom} [mm]	6.0	8.0	10.0	14.4
Thread outer diameter	d_{th} [mm]	7.45	10.50	12.70	16.55
Core diameter	d_k [mm]	5.55	7.30	9.15	13.00
Shaft diameter	d_s [mm]	5.88	7.80	9.62	13.40
Stressed section	A_s [mm ²]	23.76	42.43	65.76	132.73
Diameter of integrated washer (KB)	D [mm]	16.5	17.5	20.5	28/29.5
Diameter of integrated washer (IT)	D [mm]	14.2/17	-	-	-
Diameter of pan head (FR)	D [mm]	14.5	-	-	-
Diameter of countersunk (ST)	D [mm]	14	-	-	-

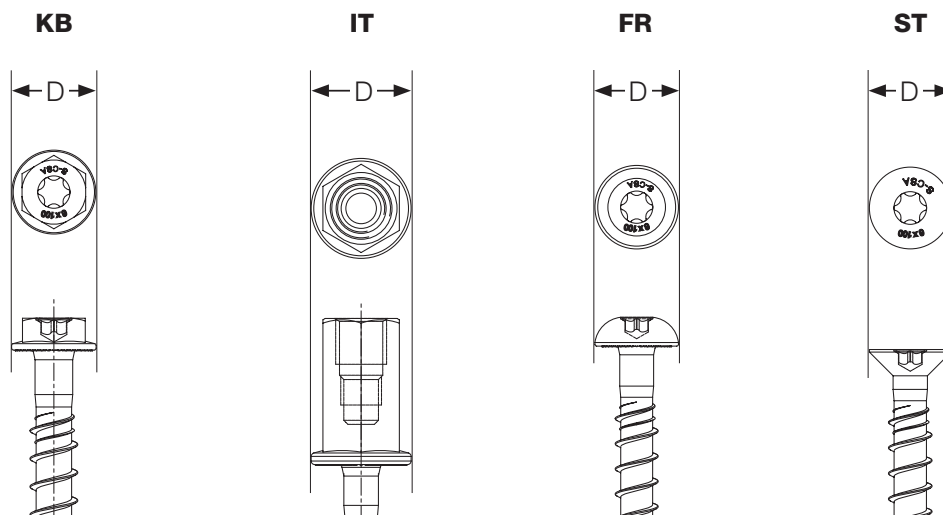

Installation instructions

Installation equipment

Specification	JC2 6	JC2 Plus 8	JC2 Plus 10	JC2 Plus 14
Rotary hammer (recommendation)	750 – 1200 r.p.m / 1.8 – 3.3 J			
Drill bit	SDS+ 2-CUT or 4-CUT sizes 6, 8, 10, 14 mm			
Socket (SW)	13 mm	13 mm	15 mm	21 or 24
T-drive / Torx	T30	-	-	-
Additional tools	air pump/compressor, torque wrench, impact screw driver			

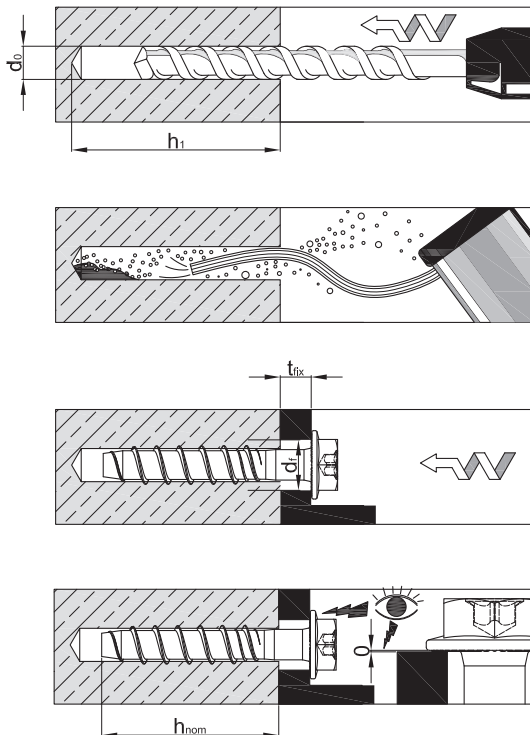

Notes

Concrete and hollow core slab

- > Concrete strength is C20/25 to C50/60. Hollow core slabs C30/37 to C50/60
- > No significant voids in concrete.
- > Concrete is well compacted.
- > Thickness of concrete is acc. PDS installation data

Installation

- > Edge distances and spacing are according PDS installation data.
- > Use proper air pump or compressor.
- > Drill hole is deep enough (mentioned h₁ in PDS installation data).
- > All dust should be cleaned from the hole to avoid screw jamming during installation.
- > Pay special attention to cleaning, especially when installing downwards.
- > In case of aborted hole, drilling of new hole at a minimum distance of twice the depth of the aborted hole, or smaller distance provided the aborted drill hole is filled with high strength non-shrinkage mortar. No shear or oblique tension loads are allowed in the direction of a not filled aborted hole.

Other base materials

- > Concrete screw can be used also in other base materials such as solid clay brick and solid sand-lime brick.

Specification	JC2 6				JC2 Plus 8		JC2 Plus 10		JC2 Plus 14		
	PART 6**	PART 6	OPT 1	OPT 1	OPT 1	OPT 1	OPT 1	OPT 1	OPT 1		
Drill hole diameter	d_0	[mm]	6		8		10		14		
Cutting diameter at the upper tolerance limit (max. diam. bit)	$d_{cut,max} \leq$	[mm]	6.40		8.45		10.45		14.50		
Depth of drilled hole to deepest point	$h_1 \geq$	[mm]	40	50	65	60	75	65	95	75	125
Effective anchorage depth	h_{ef}	[mm]	27.6	31.9	42.5	39.2	51.9	42.5	68	49.3	91.8
Nominal anchorage depth	h_{nom}	[mm]	35	40	55	50	65	55	85	65	115
Diameter of clearance hole in the fixture	d_f	[mm]	7.7 – 9.0			10.8 – 12.0		13.0 – 14.0		17.0 – 18.0	
Max. torque, manual	T_{inst}	[Nm]	14			45		85		100	
Max. torque, impact screw driver	T_{SD}	[Nm]	90			290		650		650	
Width across flats	SW	[mm]	13			13		15		21 / 24	
T-drive (in types KB, ST and FR)	T-drive		T30			-		-		-	

Installation instructions

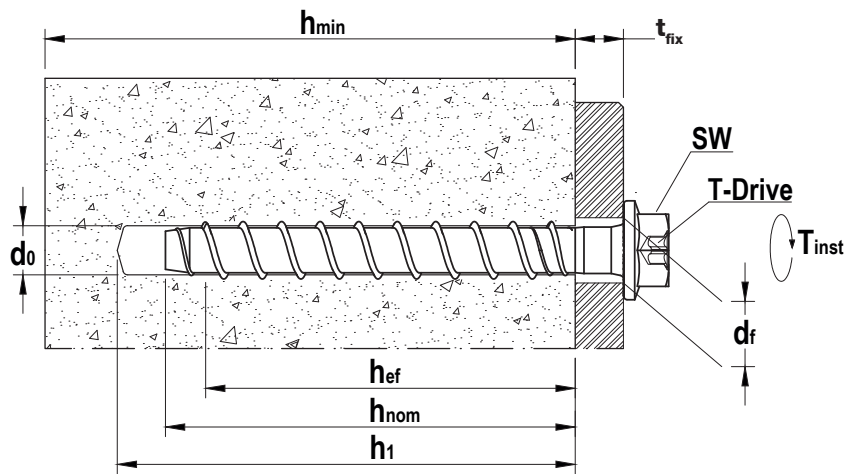

Installation parameters

Minimum thickness of concrete member, spacing and edge distance

Specification		JC2 6			JC2 Plus 8		JC2 Plus 10		JC2 Plus 14	
Approval		PART 6**	PART 6	OPT 1	OPT 1	OPT 1	OPT 1	OPT 1	OPT 1	OPT 1
Effective anchorage depth	h_{ef} [mm]	27,6	31,9	42,5	39,2	51,9	42,5	68	49,3	91,8
Nominal anchorage depth	h_{nom} [mm]	35	40	55	50	65	55	85	65	115
Minimum thickness of base materials	h_{min} [mm]	80	100	100	100	115	100	130	120	150
Minimum spacing	s_{min} [mm]	35	35	35	35	35	40	40	60	60
Minimum edge distance	c_{min} [mm]	30	35	35	35	35	40	40	60	60
Critical spacing for splitting failure and concrete cone failure (in case characteristic loading affects)	$s_{cr,sp}$ [mm]	110	96	128	118	176	128	232	148	275
	$s_{cr,N}$ [mm]	83	96	128	128	156	128	204	148	275
Critical edge distance for splitting failure and concrete cone failure (in case characteristic loading affects)	$c_{cr,sp}$ [mm]	55	48	64	59	88	64	116	74	138
	$c_{cr,N}$ [mm]	41	48	64	59	78	64	102	74	138

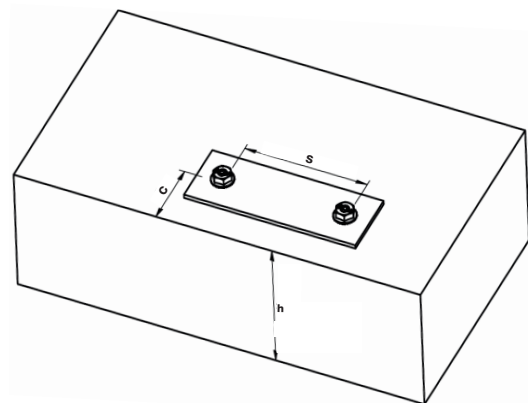

Delivery program

JC2-KB Plus	Size	t _{fix}	ETA
8	8x55	5	•
	8x70	5/20	•
	8x80	15/30	•
	8x90	25/40	•
	8x100	35/50	•
	8x120	55/70	•
	8x140	75/90	•
	10	10x60	5
10x70		15	•
10x80		25	•
10x90		5/35	•
10x100		15/45	•
10x120		35/65	•
10x140		55/85	•
10x160		75/105	•
14	14x75 SW21	10	•
	14x100 SW21	35	•
	14x130 SW21	15/65	•
	14x150 SW21	35/85	•
	14x80 SW24 *	15	•
	14x110 SW24 *	45	•
	14x130 SW24 *	15/65	•
	Zinc plated or zinc alloy coating, * = Only ZP		

JC2-KB	Size	t _{fix}	ETA
6	6x35 SW13	1	•
	6x45 SW13	5/10	•
	6x50 SW13	10/15	•
	6x60 SW13	5/20	••
	6x70 SW13	15/30	••
	6x80 SW13	25/40	••
	6x100 SW13	45/60	••
	6x120 SW13 *	65/80	••
	6x140 SW13	85/100	••
	Zinc plated or zinc alloy coating, * = Only ZP		

JC2-ST	Size	t _{fix}	ETA
6	6x45 *	5/10	•
	6x50 *	10/15	•
	6x60	5/20	••
	6x80	25/40	••
	6x100	45/60	••
	6x120 *	65/80	••
Zinc plated or zinc alloy coating, * = Only ZP			

JC2-FR	Size	t _{fix}	ETA
6	6x35 (L)	1	•**
	6x45	5	•
	6x45 (L)	5	•
	6x60	5/20	••
	Zinc plated, L = Low pan head		

JC2-IT	Size	ETA
6	6x35 M8/M10x30	•**
	6x45 M8/M10x30	•
	6x60 M8/M10x30	••
Zinc plated		

• Option 1 | • Part 6 | ** Pending



Softwarelösungen

EJOT® ANCHOR FIX – Ankerbemessung leicht gemacht

Mit der brandneuen Version ANCHOR FIX der kostenlosen Bemessungssoftware für Verankerungen bietet EJOT ein hilfreiches Werkzeug zur statischen Bemessung von Verankerungen in Ihren Projekten. Speziell für Statiker, Planer, Ingenieure und Monteure entwickelt, kann die Software auch als nützliche Orientierungshilfe in der Vorplanungsphase genutzt werden.

Mit EJOT ANCHOR FIX können Grenzzustände der Tragfähigkeit der EJOT Verankerungsprodukte wie Bolzenanker und Betonschrauben in Betonuntergründen ermittelt werden. Neu ist zudem die Möglichkeit der Bemessung von Kunststoffdübeln und chemischen Ankern in Beton und Mauerwerk.

Auch EJOT CROSSFIX® wurde nun vollumfänglich integriert. Zusätzlich ist mit der neuen Softwareversion eine Bemessung für die Lastfälle Brand und Seismik möglich. ANCHOR FIX erlaubt weiterhin die direkte Eingabe von Daten aus Baustellenauszugsversuchen und deren regelkonforme Auswertung.

EJOT ANCHOR FIX steht zum Download bereit:
www.ejot.de/software-anchorfix

Die zielgerichtete Auswahl zwischen den Berechnungsmethoden Einzel- und Mehrfachbefestigung diverser Produkte bietet dem Nutzer Verwendungssicherheit. Planungssicherheit auf Seiten des Anwenders wird durch die Ausgabe des individuellen Mengenbedarfs bei chemischen Ankern erreicht und dies auch bei variablen Setztiefen. Alle ergänzenden Dokumente wie Zulassungen und Produktdatenblätter können bequem direkt aus der Software abgerufen werden.

Testen Sie uns – kostenlos ...

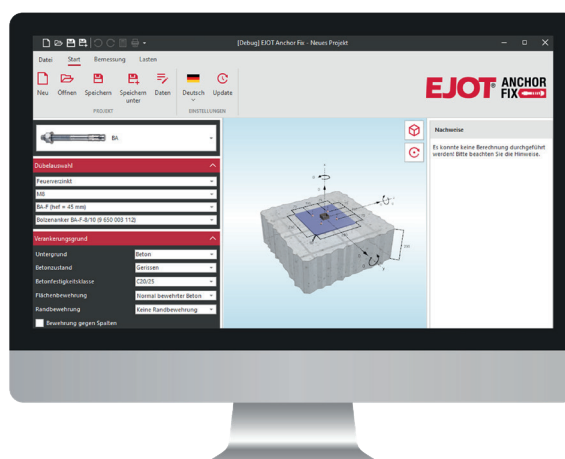

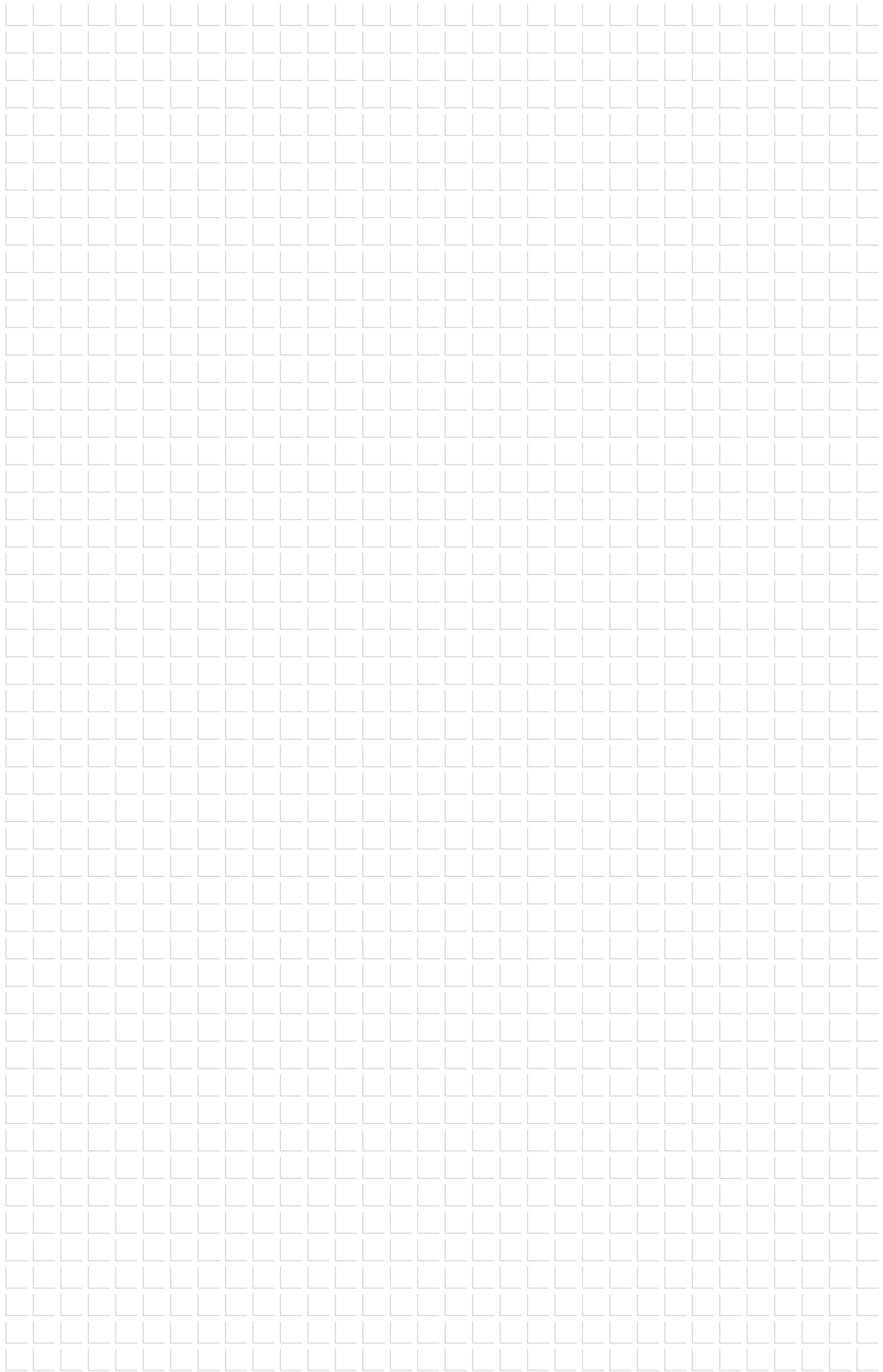



EJOT SE & Co. KG

Market Unit Construction

In der Stockwiese 35

57334 Bad Laasphe · Germany

T +49 2752 908-0

F +49 2752 908-731

construction@ejot.com

www.ejot.com/construction